

Product bill of material				
Serial number	material name	Masterial number	NO.	Describe
①	4-2316-A	94.04.2316.000	1	Material:T=1.0mm 1090AL
②	020249	97.76.249.00	1	Material:T=0.6mm SUS304

table for unmentioned tolerance in the drawing (unit: mm)			punch angle tolerance in the drawing (unit:degree)		
0-5	5-30	30-120	0-10	10-50	50-120
±0.15	±0.2	±0.5	±1°	±0.5°	±0.3°
120-250	250-400	400-700	120-250	250-360	360 above
±0.8	±1.5	±2	±0.2°	±0.166°	±0.083°

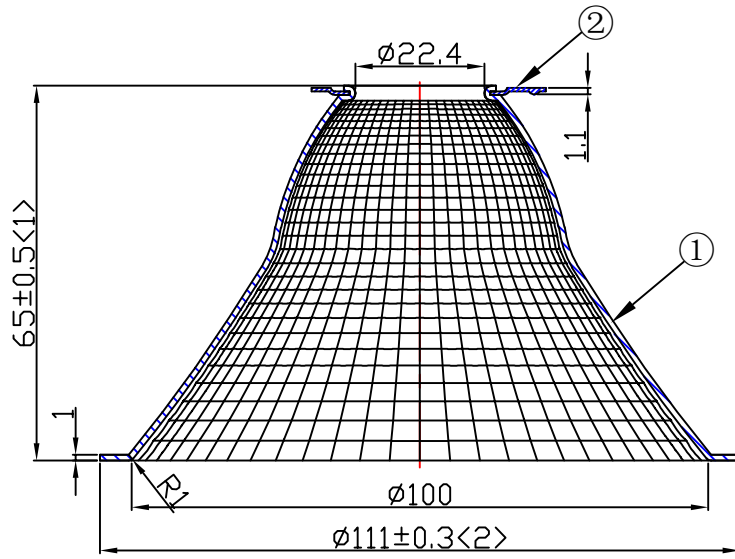

A-A

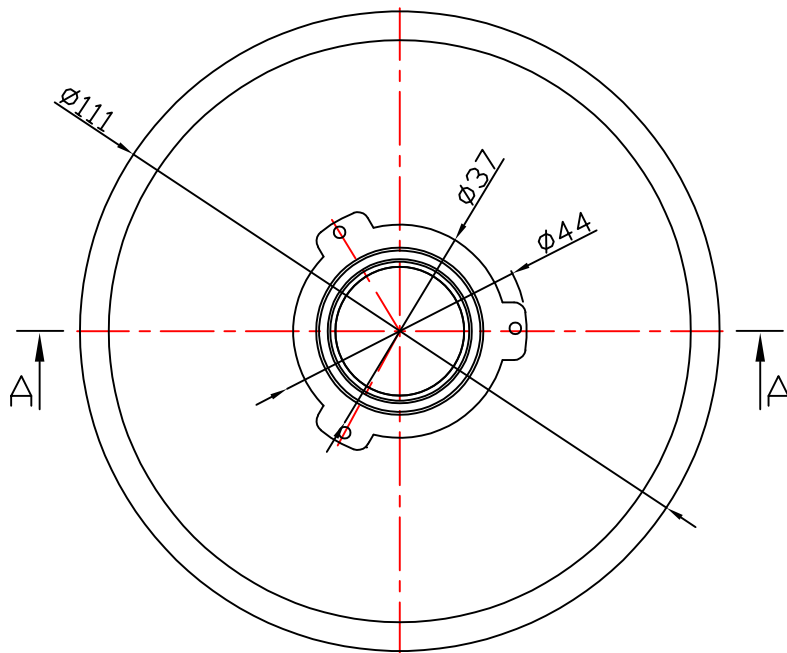

Light Source	XICATO XTM 19MM
Plastic Holder	
Metal Adaptor	
Design Angle	$40 \pm 3^\circ$
Measured Angle	39.2°

Mark	Amended Times	Amended Content	Signature	Amended Date	 Nata[®] NATA Lighting Co.,Ltd
Controll Version	A2	Design Version	KO	Client Version	
Designer		Drawing by		Proportion	
Technology		Auditor		View	
Approval		Date	2018.03.05	Page	
				Total Page	Customer Item
					Customer Code
					Product Number
					Product Name
					4-1984-M